

### Features

- High DC current gain
- Complimentary to SS8550

HF

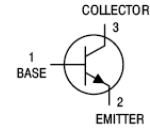

### Mechanical Data

- Case: SOT-89
- Molding compound: UL flammability classification rating 94V-0
- Terminals: Tin-plated; solderability per MIL-STD-202, Method 208

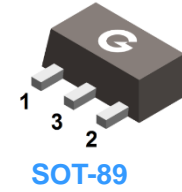

### Ordering Information

Part Number	Package	Shipping Quantity	Marking Code
SS8050	SOT-89	1000 pcs / Tape & Reel	Y1

### Maximum Ratings (@ T<sub>A</sub> = 25°C unless otherwise specified)

Parameter	Symbol	Value	Unit
Collector-Base Breakdown Voltage	V <sub>CB0</sub>	40	V
Collector-Emitter Breakdown Voltage	V <sub>CEO</sub>	25	V
Emitter-Base Breakdown Voltage	V <sub>EBO</sub>	6	V
Collector Current (Continuous)	I <sub>C</sub>	1.5	A
Collector Current (Peak)	I <sub>CM</sub>	2	A

### Thermal Characteristics

Parameter	Symbol	Value	Unit
Power Dissipation (T <sub>A</sub> = 25°C) *1	P <sub>D</sub>	0.5	W
Power Dissipation (T <sub>A</sub> = 25°C, based on R <sub>θJA</sub> (Typ.) = 175°C/W)	P <sub>D</sub>	0.7	W
Thermal Resistance Junction-to-Air *1	R <sub>θJA</sub>	250	°C/W
Operating Junction Temperature Range	T <sub>J</sub>	-55 ~ +150	°C
Storage Temperature Range	T <sub>STG</sub>	-55 ~ +150	°C

Note 1: The data tested by surface mounted on a minimum recommended FR-4 board

**Electrical Characteristics** (@  $T_A = 25^\circ\text{C}$  unless otherwise specified)

Parameter	Symbol	Test Condition	Min.	Typ.	Max.	Unit
Collector-Base Breakdown Voltage	$V_{(BR)CBO}$	$I_C = 100\mu\text{A}, I_E = 0$	40	-	-	V
Collector-Emitter Breakdown Voltage	$V_{(BR)CEO}$	$I_C = 2\text{mA}, I_B = 0$	25	-	-	V
Emitter-Base Breakdown Voltage	$V_{(BR)EBO}$	$I_E = 100\mu\text{A}, I_C = 0$	6	-	-	V
Collector Cut-off Current	$I_{CBO}$	$V_{CB} = 35\text{V}, I_E = 0$	-	-	0.1	$\mu\text{A}$
Collector Cut-off Current	$I_{CEO}$	$V_{CE} = 20\text{V}, I_B = 0$	-	-	0.1	$\mu\text{A}$
Emitter Cut-off Current	$I_{EBO}$	$V_{EB} = 6\text{V}, I_C = 0$	-	-	0.1	$\mu\text{A}$
DC Current Gain	$h_{FE}$	$V_{CE} = 1\text{V}, I_C = 0.1\text{A}$	120	-	400	-
		$V_{CE} = 1\text{V}, I_C = 0.8\text{A}$	40	-	-	-
Collector-emitter Saturation Voltage	$V_{CE(sat)}$	$I_C = 0.8\text{A}, I_B = 0.08\text{A}$	-	0.28	0.5	V
Base-emitter Saturation Voltage	$V_{BE(sat)}$	$I_C = 0.8\text{A}, I_B = 0.08\text{A}$	-	0.98	1.2	V
Base-emitter on Voltage	$V_{BE(on)}$	$V_{CE} = 1\text{V}, I_C = 10\text{mA}$	-	0.66	1	V
Transition Frequency	$f_T$	$I_C = 50\text{mA}, V_{CE} = 10\text{V}$	100	-	-	MHz
Collector Output Capacitance	$C_{OB}$	$V_{CB} = 10\text{V}, I_E = 0, f = 1\text{MHz}$	-	15	-	pF

**Classification of  $h_{FE}$** 

Rank	L	H	J
Range	120-200	200-350	300-400

Ratings and Characteristics Curves (@  $T_A = 25^\circ\text{C}$  unless otherwise specified)

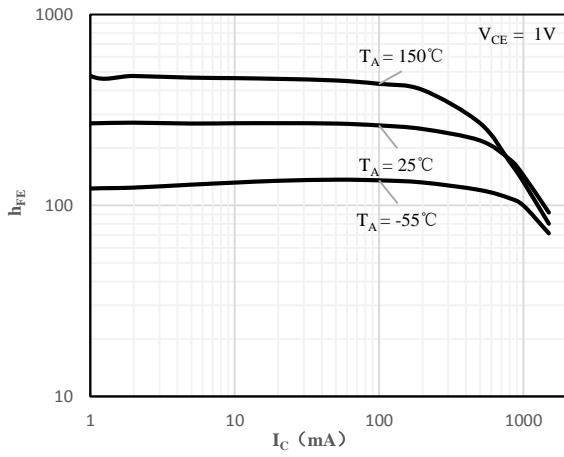

Fig 1  $h_{FE}$  vs.  $I_C$  (H)

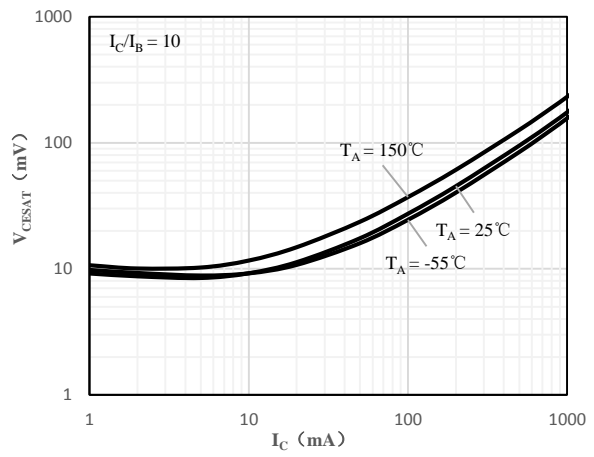

Fig 2  $V_{CE(sat)}$  vs.  $I_C$

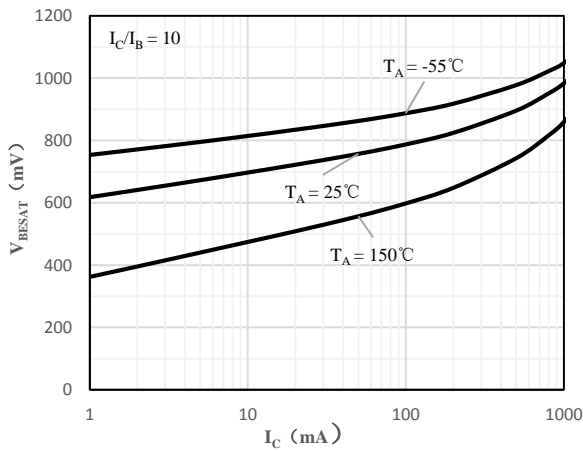

Fig 3  $V_{BE(sat)}$  vs.  $I_C$

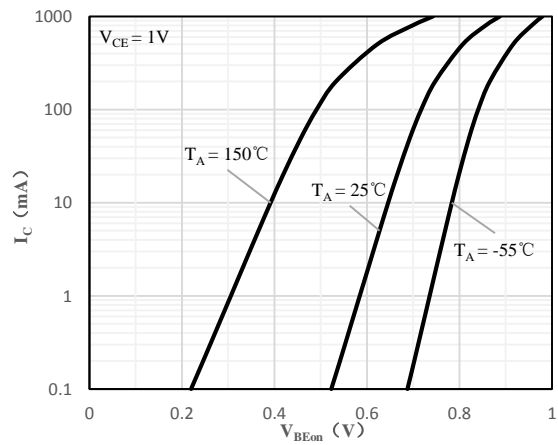

Fig 4  $V_{BE(ON)}$  vs.  $I_C$

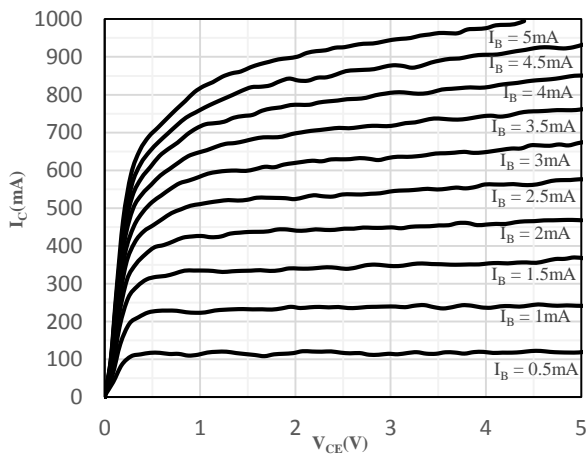
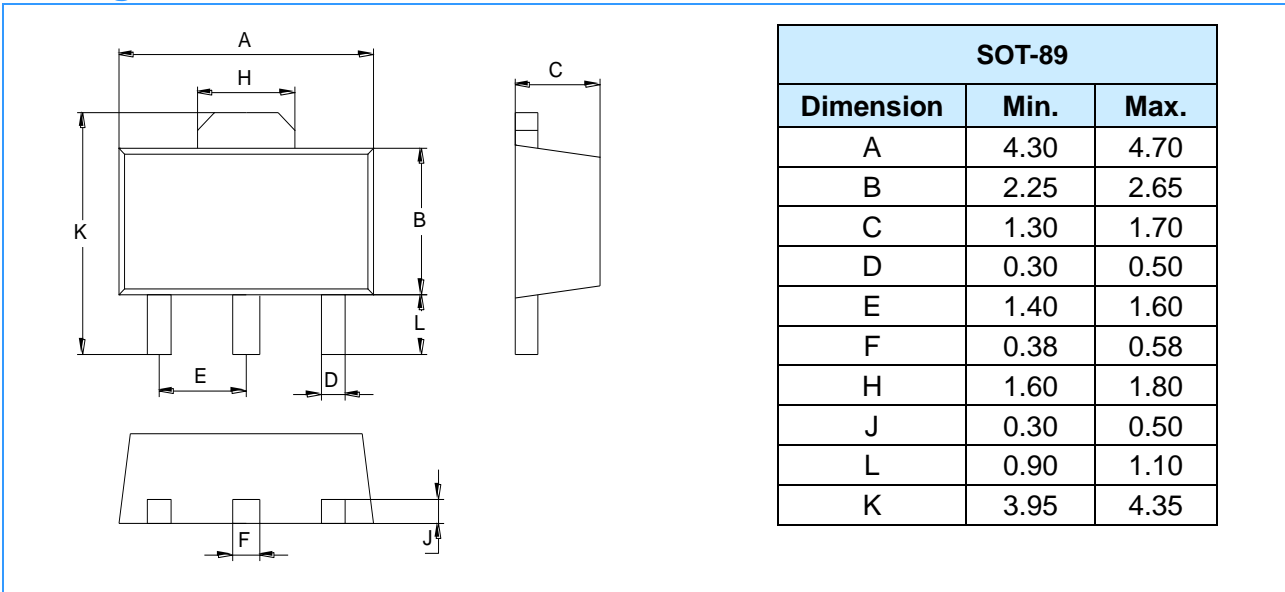
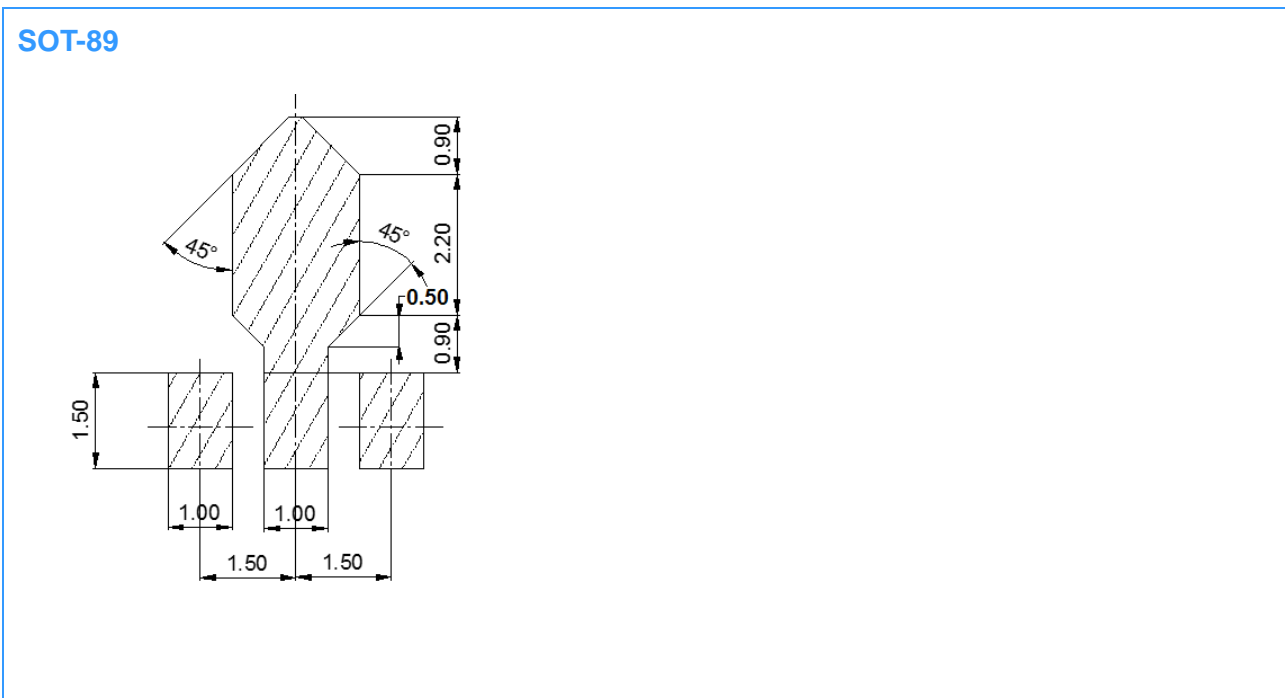

Fig 5  $I_C$  vs.  $V_{CE}$

Package Outline Dimensions (Unit: mm)



Mounting Pad Layout (Unit: mm)



IMPORTANT NOTICE

Changzhou Galaxy Century Microelectronics (GME) reserves the right to make changes without further notice to any product information (copyrighted) herein to make corrections, modifications, improvements, or other changes. GME does not assume any liability arising out of the application or use of any product described herein; neither does it convey any license under its patent rights, nor the rights of others.