

SuperPlanar™ Bridge Rectifiers

GBU6J--GBU6K

Features

- Planar passivated chips
- Ultra low leakage reverse current
- High temperature performance
- High surge current capability
- Ideal for printed circuit boards
- High temperature soldering guaranteed:260°C/10 seconds
- RoHS Compliant

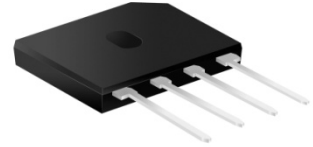

Mechanical Data

- Case: GBU molded plastic
- Molding compound, UL flammability classification rating 94V-0
- Terminals: Leads solderable per MIL-STD-750,
- Mounting position: Any

Maximum Ratings (@T_A = 25°C unless otherwise specified)

Characteristic		Symbol	GBU6J	GBU6K	Units
Peak repetitive reverse voltage		V _{RRM}	600	800	V
RMS reverse voltage		V _{RMS}	420	560	V
DC blocking voltage		V _{DC}	600	800	V
Maximum average forward output current		I _{F(AV)}	6.0		A
Peak forward surge current, 8.3ms single half-sine-wave	@T _J = 25°C	I _{FSM}	170		A
I ² t Rating for fusing	@T _J = 25°C	I ² t	120		A ² s

Thermal Characteristics

Parameter	Symbol	GBU6J	GBU6K	Units
Typical thermal resistance per leg (Note 1,Note2)	R _{θJA} (2)	35		°C /W
	R _{θJC} (1)	4.2		
Operating junction temperature range	T _J	- 55 ---- + 150		°C
Storage temperature range	T _{STG}	- 55 ---- + 150		°C

Note:

- (1) Unit case mounted on 65mm x 50mm x2.4mm aluminum plate heatsink
- (2) Units mounted on PCB without heatsink

SuperPlanar™ Bridge Rectifiers

GBU6J--GBU6K

Electrical Characteristics (@T_A = 25°C unless otherwise specified)

Parameter	Symbol	Test conditions	Typ.	Max.	Units	
Maximum instantaneous forward voltage	V _F	I _F =3.0A Per Diode	0.91	0.95	V	
		I _F =6.0A Per Diode	0.94	1.0		
Maximum Reverse current	I _R	Rated V _R , Per Diode	@T _A =25°C	0.2	1.0	μA
			@T _A =150°C	40	100	

SuperPlanar™ Bridge Rectifiers

GBU6J--GBU6K

Ratings and Characteristic Curves ($T_A=25^\circ\text{C}$ unless otherwise noted)

Fig.1-Forward Current Derating Curve

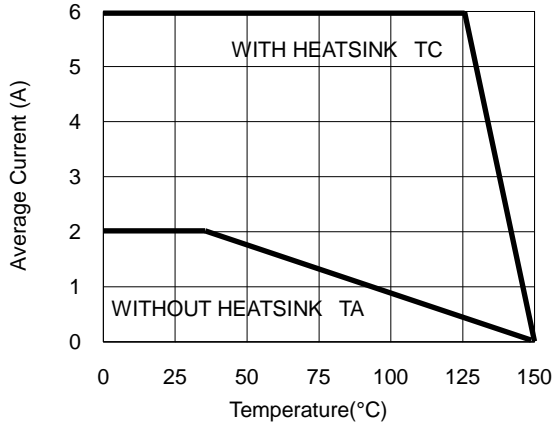

Fig.2- Surge Current Derating Curve

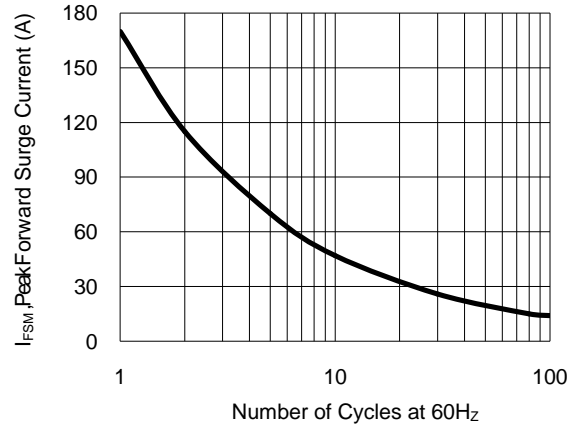

Fig.3- Typical Forward Voltage Characteristic

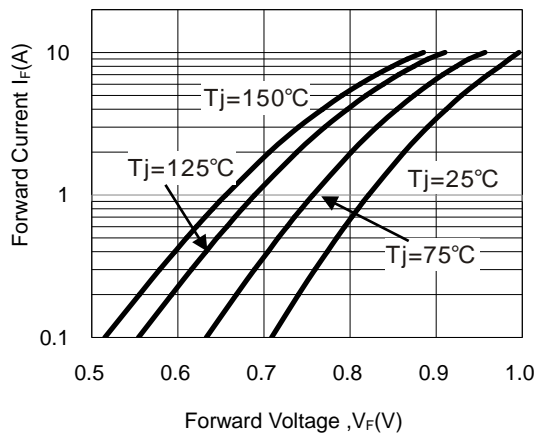
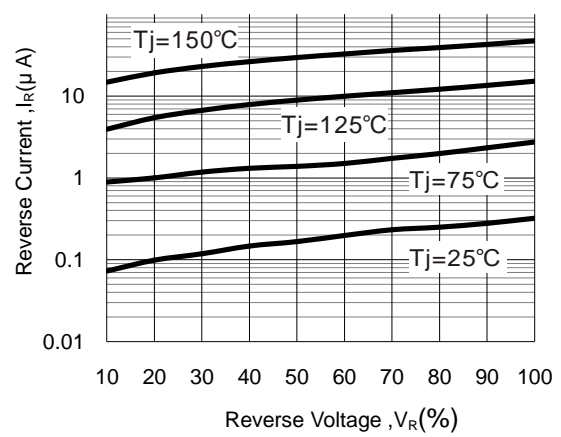

Fig.4- Typical Reverse Characteristic



SuperPlanar™ Bridge Rectifiers

GBU6J--GBU6K

Package Outline Dimensions(unit:mm)

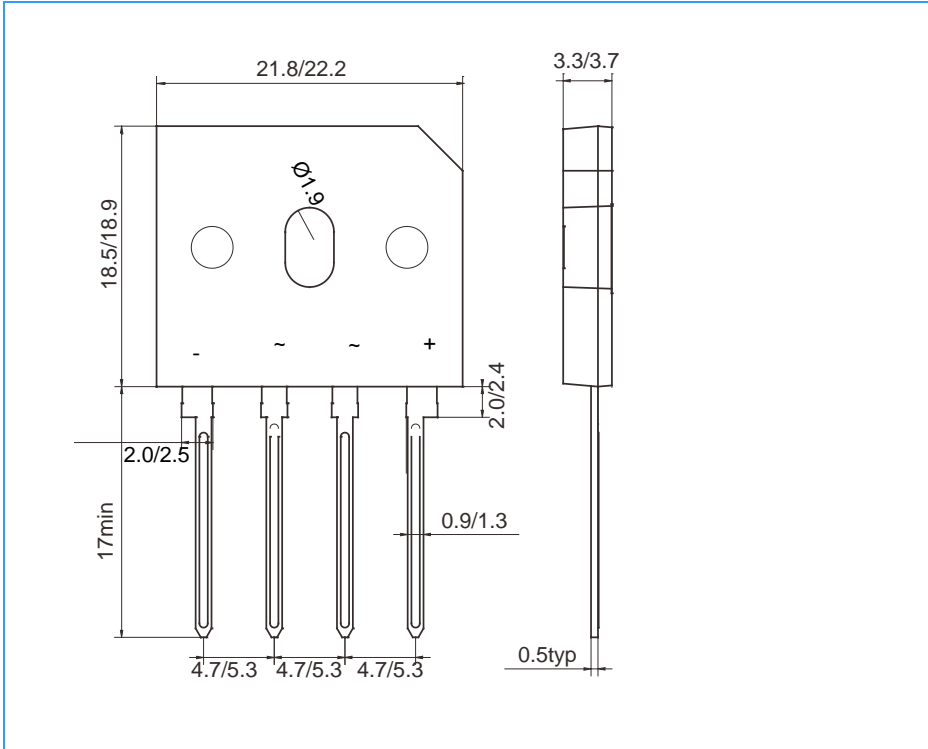

Ordering Information

Part No.	Marking	Package
GBU6J	GBU6J	GBU
GBU6K	GBU6K	GBU